

# ASSEMBLY & PREPARATION MANUAL

©1975 Kawasaki Motors Corp., U.S.A.  
PRINTED IN USA

# KAWASAKI KT 250

ASSEMBLY INSTRUCTIONS ..... Work performed during uncrating and setup  
PREPARATION ..... Pre-sale servicing and inspection  
SPECIFICATIONS ..... Handy specifications for possible troubleshooting

No liability can be accepted for any inaccuracies or omissions in this publication, although every possible care has been taken to make it as complete and accurate as possible. All procedures and specifications subject to change without prior notice.

All rights reserved. No part of this publication may be reproduced, stored in a retrieval system, or transmitted in any form or by any means, electronic mechanical photocopying, recording or otherwise, without the prior written permission of Technical Services/Kawasaki Motors Corp., U.S.A.



# ASSEMBLY

1

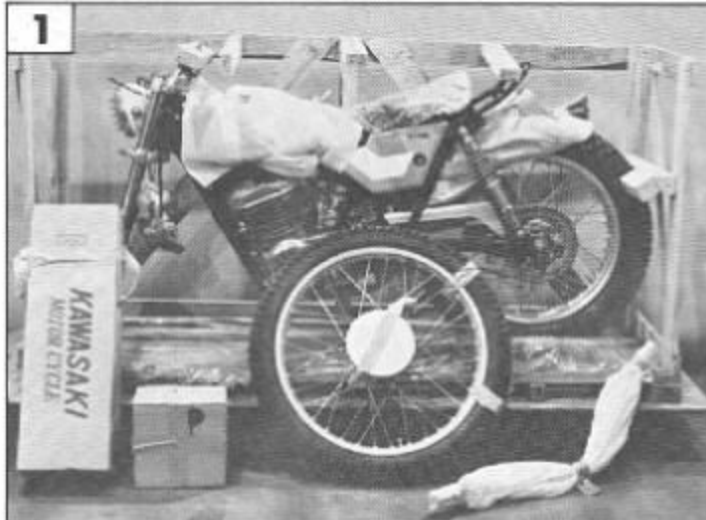

Clear work area. Set crate upright on base and remove cover. Remove long side of crate (either side).

**CAUTION:** BEND OVER ALL EXPOSED NAILS TO PREVENT INJURY OR A TIRE PUNCTURE. You should have two parts boxes, front wheel, handlebar, and rear fender assembly (tied to rear wheel).

2

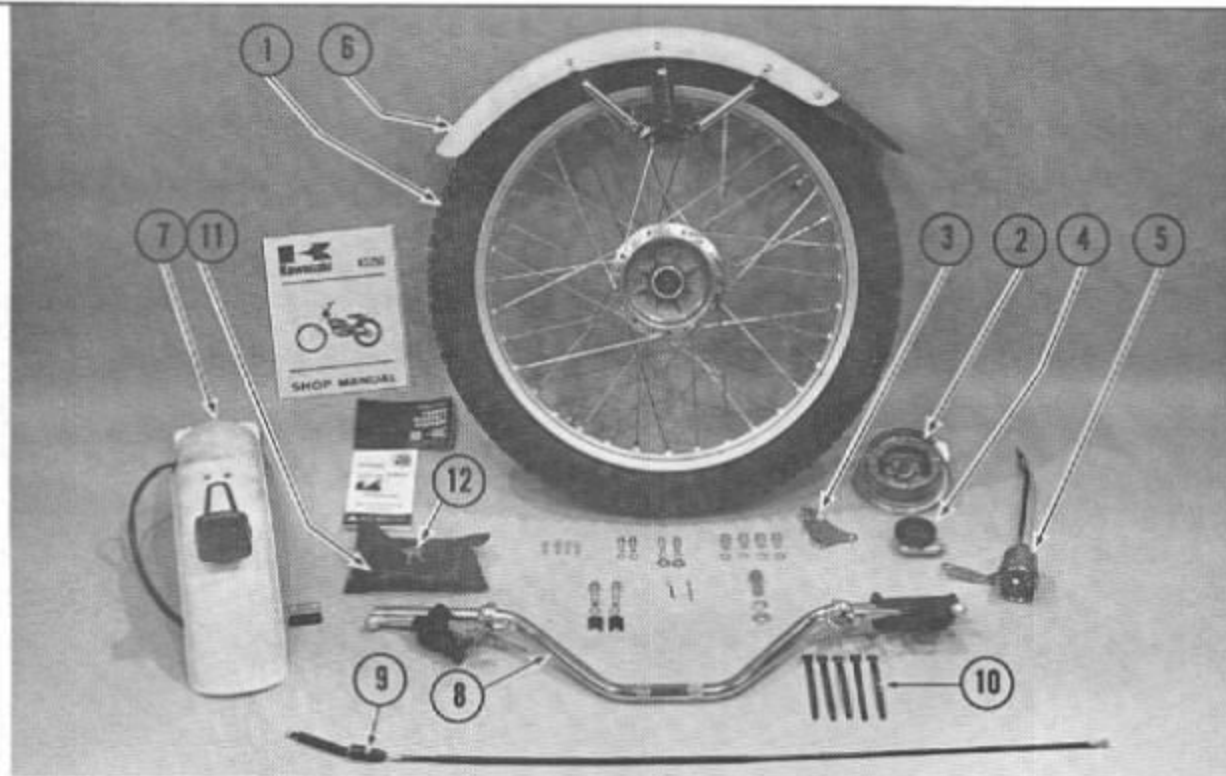

Open parts boxes and check for damage or missing parts:

- 1 Front wheel
- 2 Front brake panel
- 3 Front brake cable anchor and adjuster
- 4 Speedometer drive gearbox
- 5 Speedometer assembly with cable
- 6 Front fender assembly (clean with steel wool)
- 7 Rear fender assembly
- 8 Handlebar assembly
- 9 Front brake cable
- 10 5 cable ties

11 Tool kit

12 2 ignition keys

Owner's Warranty Handbook  
Motorcycle Safety Pamphlet  
KT250 Shop Manual  
Nuts, bolts, and fasteners:

- 1 bolt, lockwasher, flat washer for front brake panel anchor.
- 2 bolts with locknuts for rear fender.
- 2 bolts with lockwasher and flat washer for rear fender.
- 4 Phillips head screws for light switch case and twistgrip mounting.
- 4 bolts with lockwashers for front fender mounting.
- 2 bolts with lockwashers and weldnuts for seat mounting.
- 2 cotter keys.

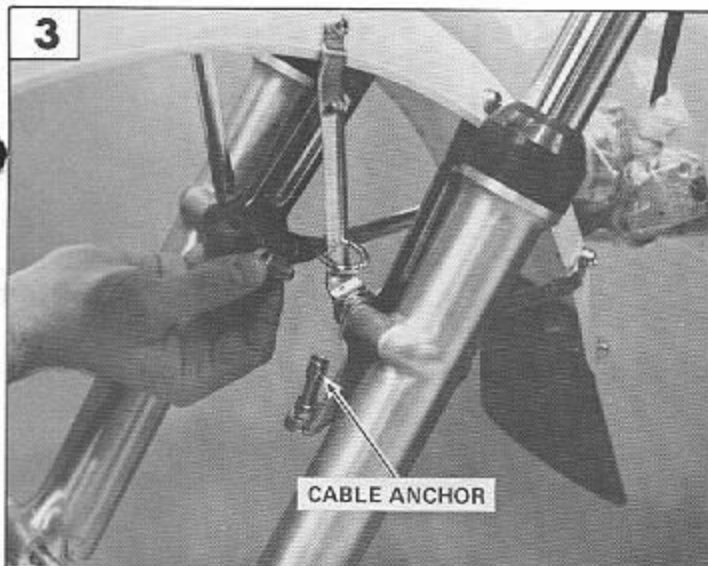

Remove motorcycle from crate and prop up securely at skid pan.

Position front fender with flap to the rear, between fork tubes. Insert front brake cable anchor and adjuster assembly between left fork tube and front fender. Install two 18mm long bolts and lockwashers and tighten to 1.9 kg-m (14 ft-lb).

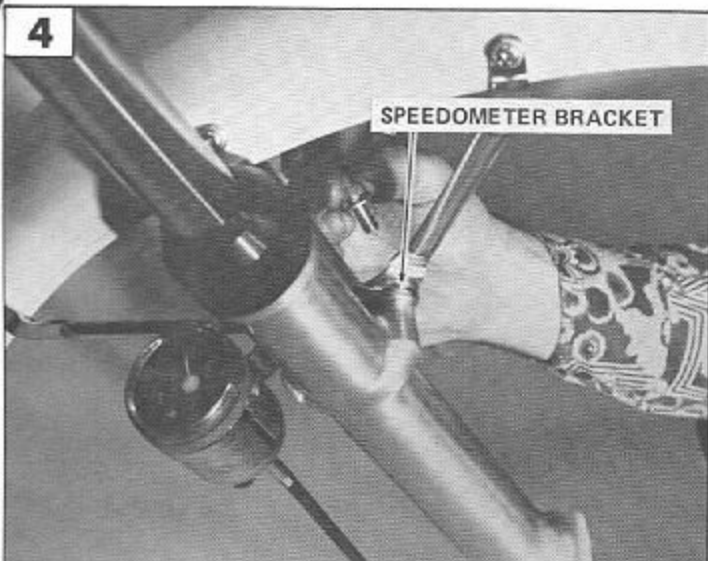

Insert speedometer bracket between right fork leg and front fender bracket. Install two 18mm long bolts and lockwashers and tighten to 1.9 kg-m (14 ft-lb).

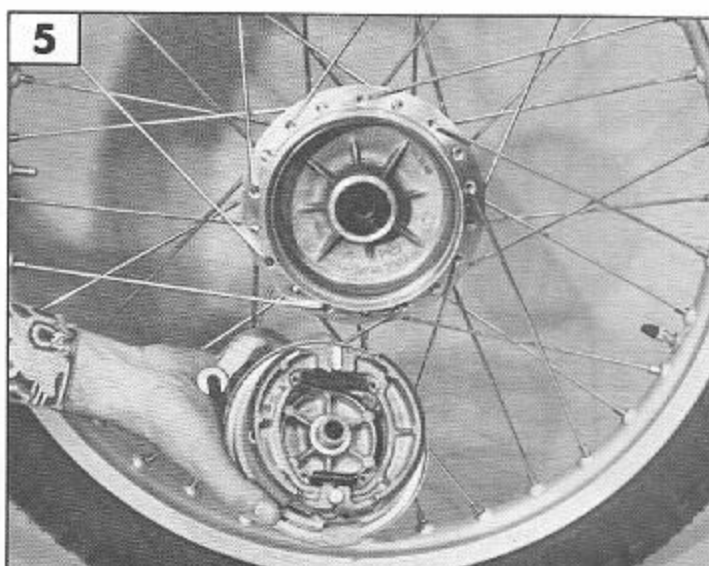

Clean front brake drum with trichlorethylene or other oilless solvent (electric contact cleaner). Install front brake panel in wheel.

**WARNING:** LOOSE PARTS IN THE HUB OR BRAKE ASSEMBLY CAN RESULT IN DAMAGE OR COULD CAUSE THE FRONT WHEEL TO LOCK, RESULTING IN LOSS OF CONTROL.

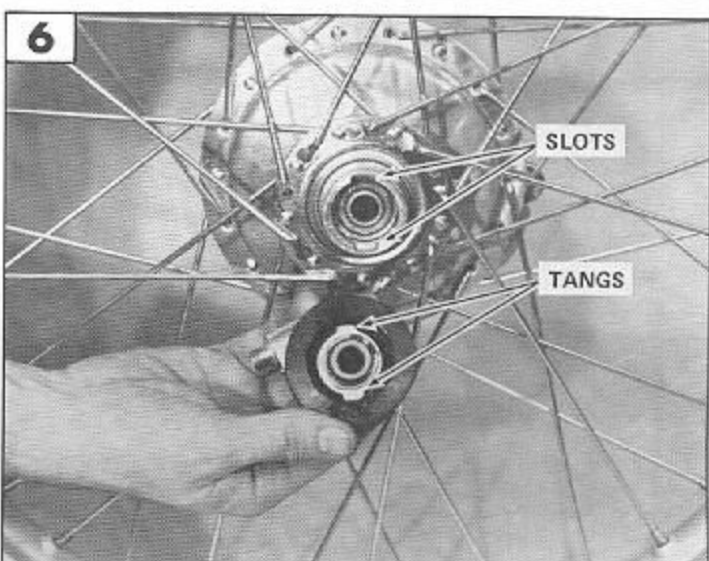

Lubricate speedometer drive gearbox with grease and install gearbox on wheel. Make sure tangs on gearbox align with slots in wheel hub.

**WARNING:** MISALIGNED DRIVE COMPONENTS CAN RESULT IN DAMAGE OR COULD CAUSE THE FRONT WHEEL TO LOCK, RESULTING IN LOSS OF CONTROL.

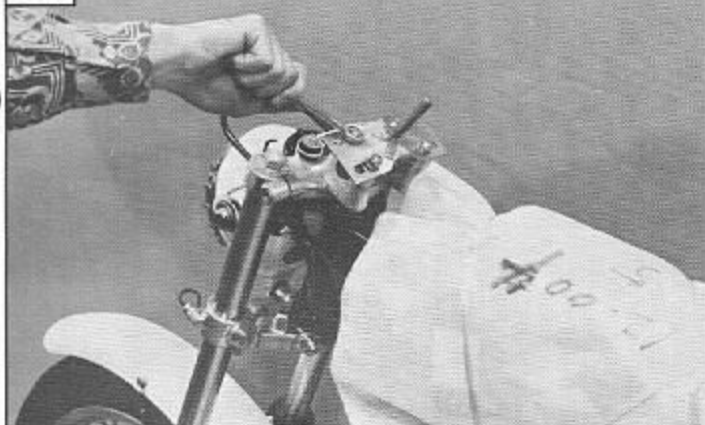

**13**

Remove wooden cross brace and metal plate from handlebar mount.

**16**

GROMMET

Slide grommet up engine stop wire into twistgrip housing.

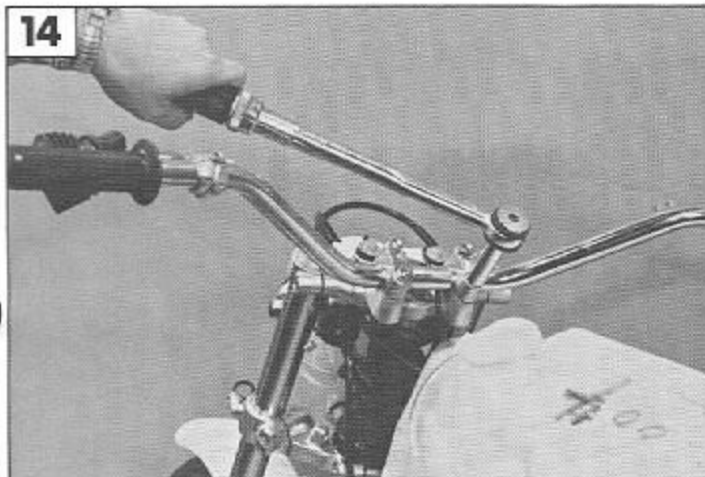
**14**

Install handlebars and clamps. Torque mounting bolts to 1.8 kg-m (13 ft-lb).

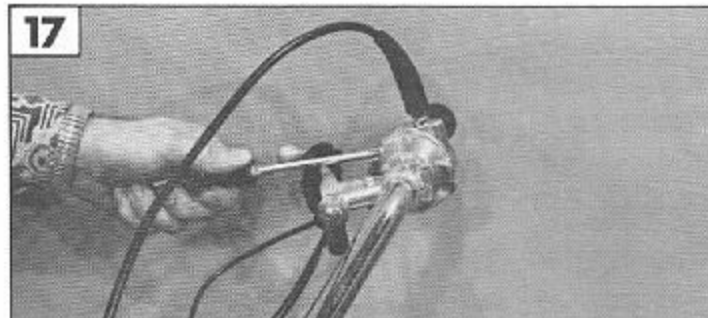
**17**

Install twistgrip case mounting screws and tighten securely.

**WARNING:** DO NOT PUSH TWISTGRIP ASSEMBLY ONTO HANDLEBAR SO FAR THAT INSIDE OF GRIP CONTACTS END OF HANDLEBAR. THIS CAN INTERFERE WITH THROTTLE ACTION AND COULD RESULT IN LOSS OF CONTROL.

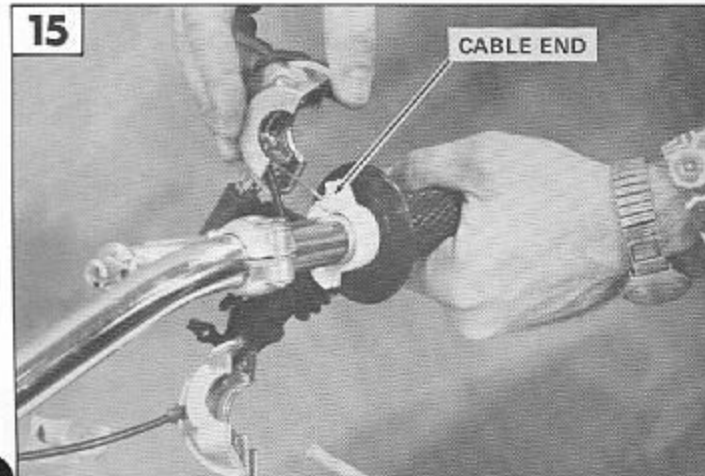
**15**

CABLE END

Slide throttle twist grip assembly on end of handlebar. Connect throttle cable end to throttle twistgrip.

**18**

GUIDE RINGS

Install front brake cable. Feed upper end of brake cable through two guide rings.

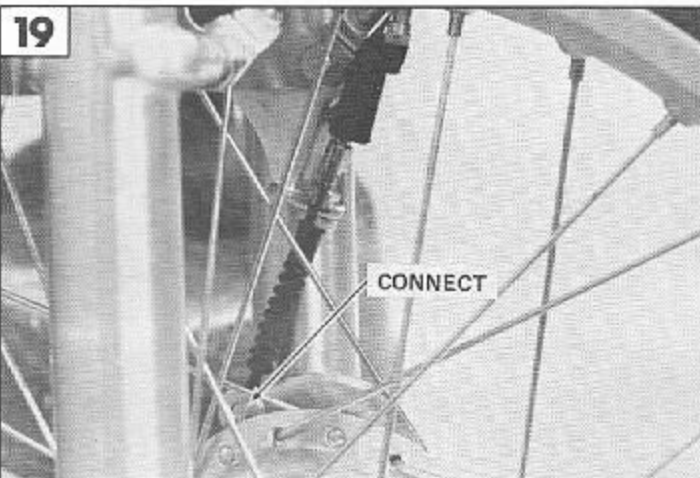
**19**

CONNECT

Connect bottom end of brake cable to anchor plate and cam lever.

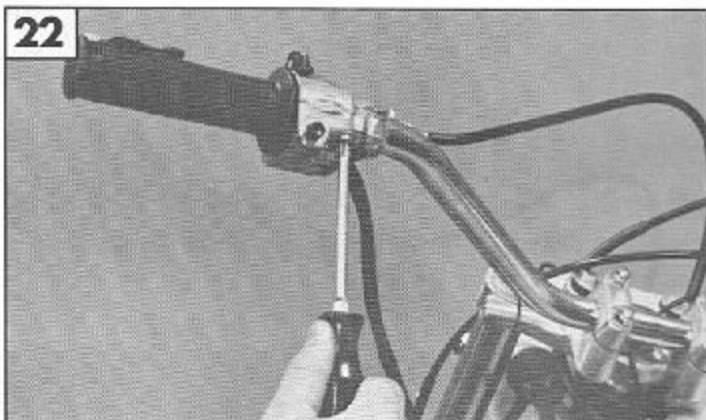
**22**

Install light switch case. Tighten mounting screws securely.

**CAUTION:** AVOID PINCHING WIRE LEADS BETWEEN CASE HALVES WHEN TIGHTENING SCREWS.

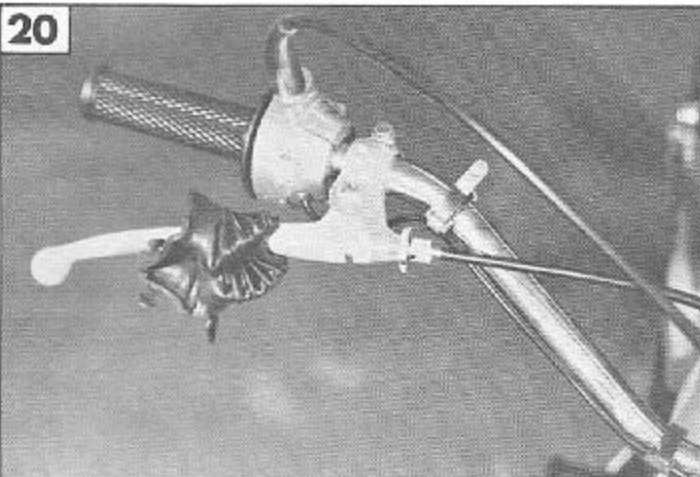
**20**

Connect upper end of brake cable to brake lever, and install dust cover.

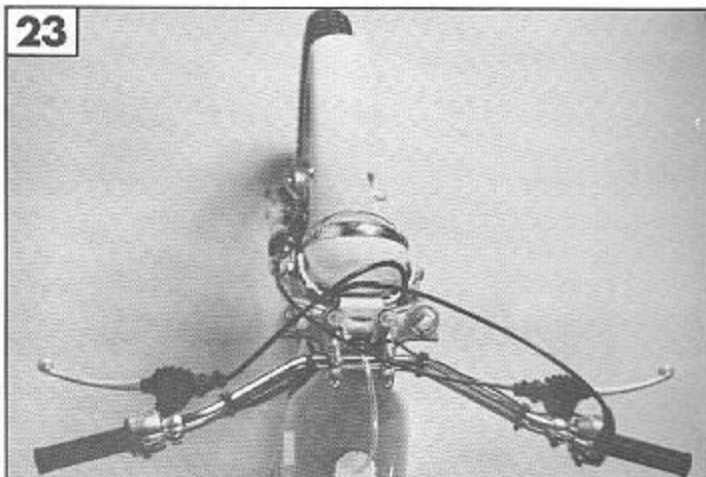
**23**

Install 4 cable ties on handlebars. Check brake cable, clutch cable, and throttle cable routing.

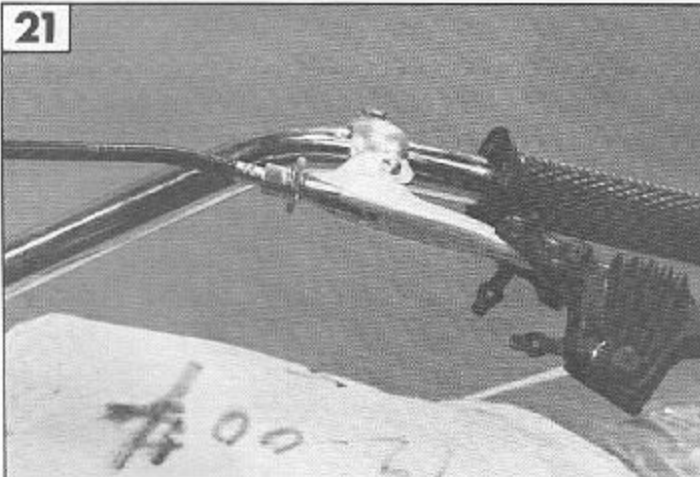
**21**

Connect clutch cable to clutch lever, and install dust cover.

**24**

Remove seat temporarily. Slide seat backwards and pull up.

25

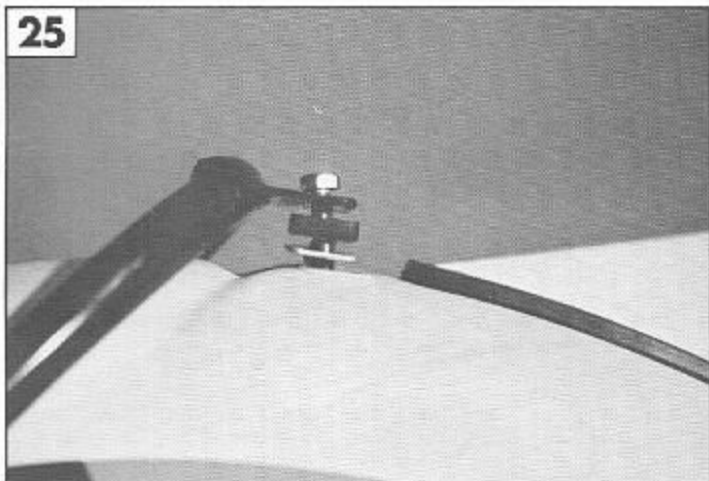

Install rear fender. Use metal plate, rubber insulator, 2 bolts and locknuts at rear of fender.

28

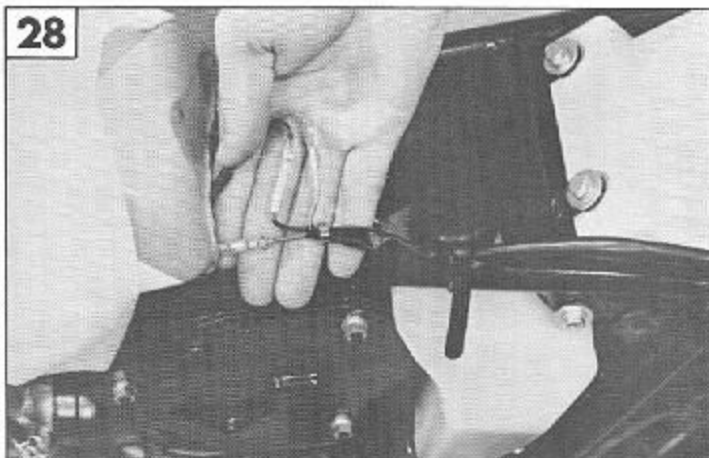

Connect three color-coded wires from tail light to corresponding color-coded wires emerging from under gas tank. Use two cable ties on wire from tail light.

26



Use 2 bolts, lockwashers and flat washers at front of fender. If forward mounting bolts will not go in, see next step. If bolts go in, tighten them and skip next step.

29

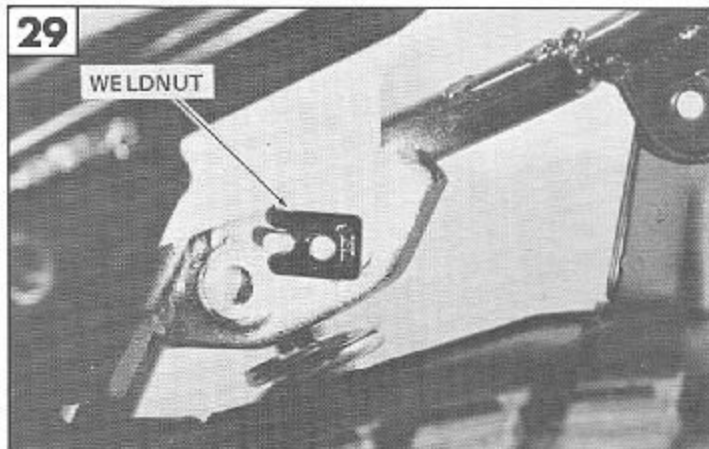

Install seat. Avoid catching forward bracket of seat on tail light wires. Insert 2 bolts and lockwashers through bracket and seat and into weldnut.

27

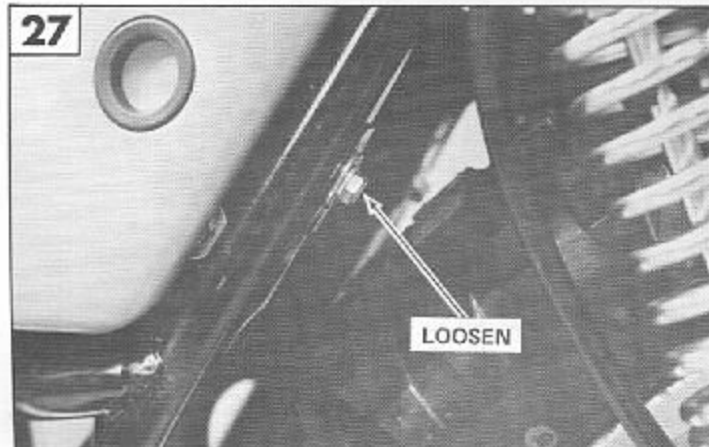

Temporarily loosen bracket bolts on rear frame in back side of panels until fender bolts will screw in. Tighten bracket bolts and mounting bolts.

30

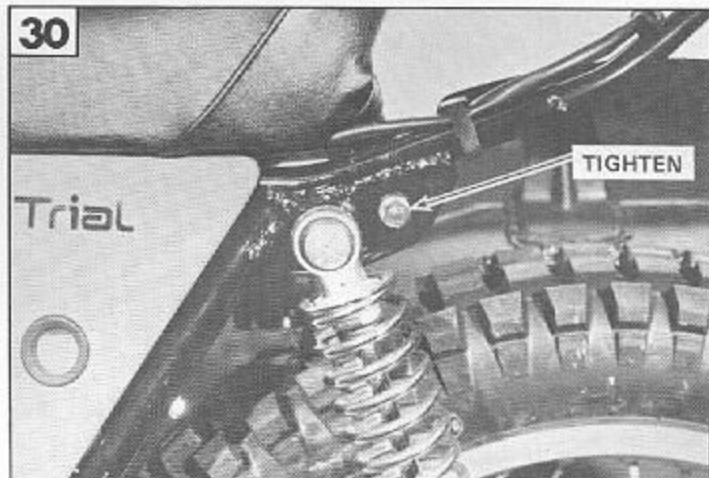

Tighten seat mounting bolts.

**31**

Remove protecting coverings from tank, seat, and muffler.

**32**

Check your Service Binder for any Service Bulletins specifying Factory Directed Modifications which must be performed before the motorcycle is ready for sale.

**ASSEMBLY COMPLETE**



## PREPARATION

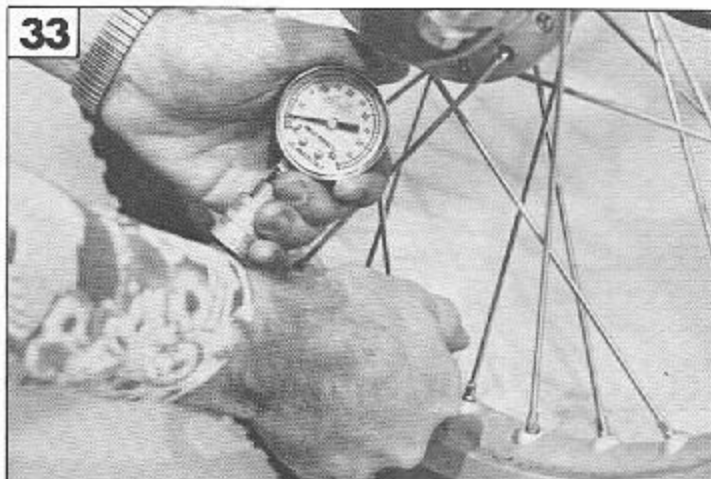

Check tire air pressure and adjust to 0.35 kg/cm<sup>2</sup> (5 PSI).

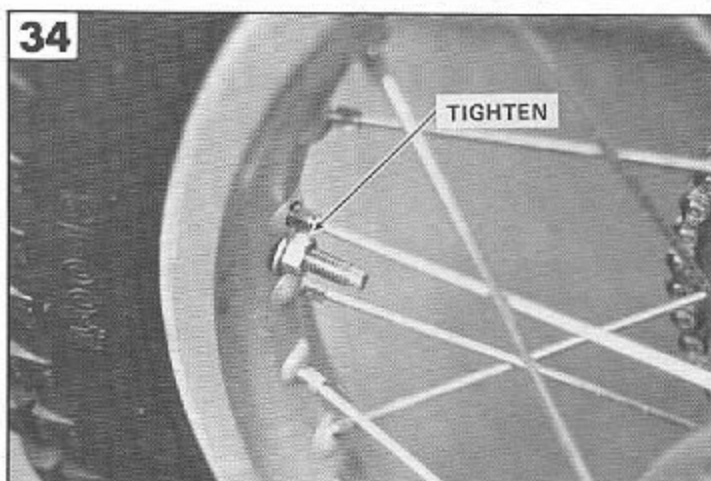

Check/tighten bead protector nuts.

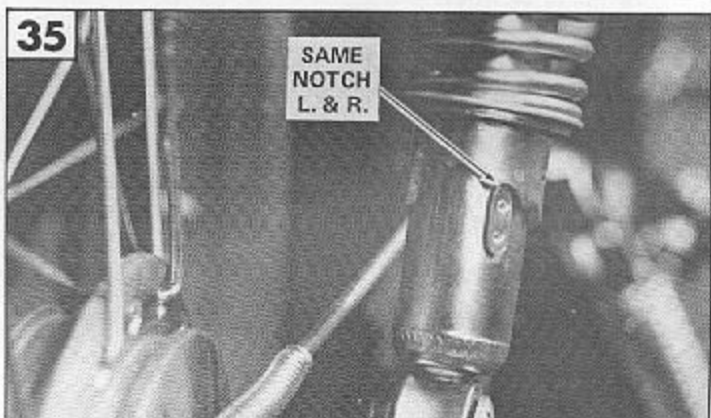

Adjust rear shock absorbers for equal spring tension, left and right.

**CAUTION:** IF REAR SHOCK ABSORBERS ARE NOT ADJUSTED EQUALLY, HANDLING MAY BE IMPAIRED.



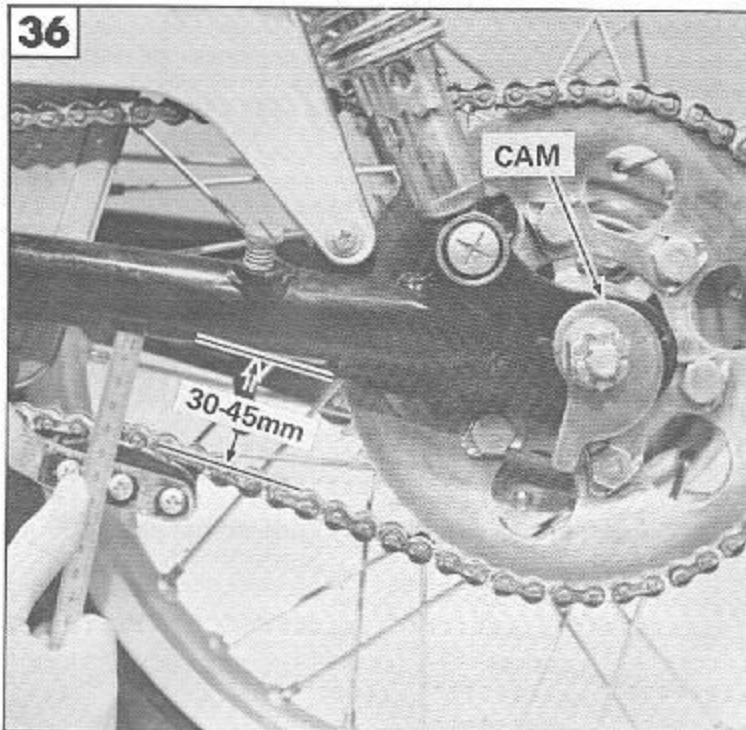

Check drive chain adjustment and wheel alignment. Adjust if required.

- Rotate wheel to find tightest part of chain.
- With motorcycle on side stand, measure space between chain and swing arm at center of tensioner. There should be 30-45mm.
- Check that left and right snail cam adjusters on axle are positioned at same reference marks. This checks wheel alignment.

**CAUTION:** TO INSURE PROPER WHEEL AND SPROCKET ALIGNMENT, THE LEFT AND RIGHT ADJUSTERS MUST BE POSITIONED AT THE SAME REFERENCE MARKS (CHECK NUMBERS AND MARKS STAMPED ON ADJUSTERS). MISALIGNMENT OF THE SPROCKET OR WHEEL WILL RESULT IN ABNORMAL WEAR AND MAY RESULT IN IMPAIRED HANDLING. If drive chain requires adjustment, or if wheel needs aligning; finish this step. Otherwise, proceed to rear brake adjustment.

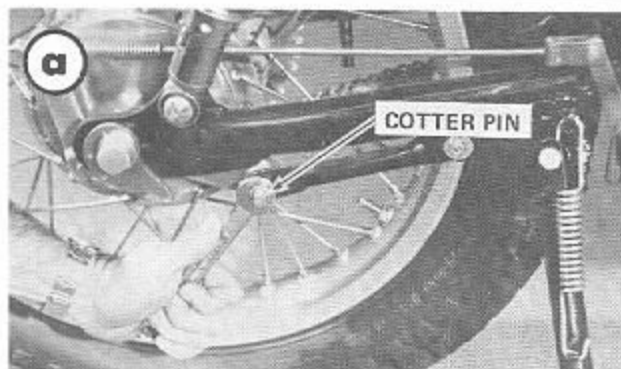

- Loosen torque link nut. Remove cotter pin, if required.
- Remove cotter pin and loosen rear axle nut.
- Turn snail cam adjusters until chain adjustment is correct.

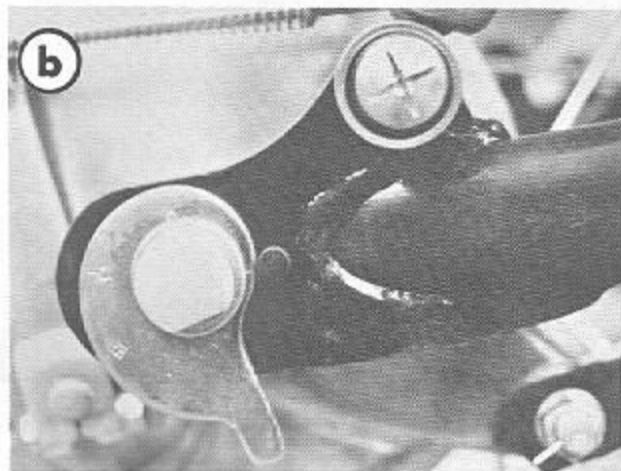

- Adjusters must be snug against stop pins in front of adjusters.



- Tighten axle nut to 9 kg-m (65 ft-lb). Recheck drive chain adjustment.

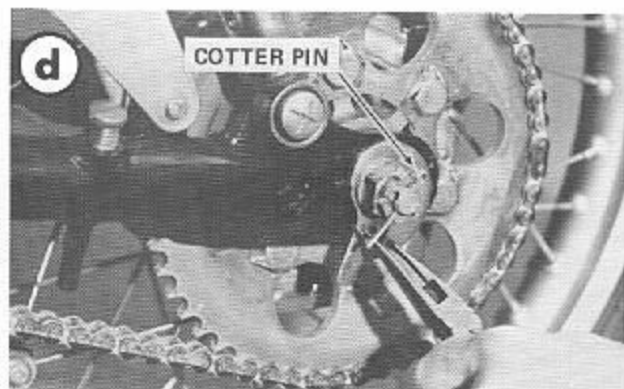

- Install a new cotter pin through the axle nut; spread the ends.

**WARNING:** IF THE AXLE NUT IS NOT SECURELY TIGHTENED, AND THE COTTER PIN IS NOT INSTALLED, AN UNSAFE RIDING CONDITION MAY EXIST.

- Tighten the torque link nut to 2.8 kg-m (20 ft-lb). Install a new cotter pin if required; spread the ends.

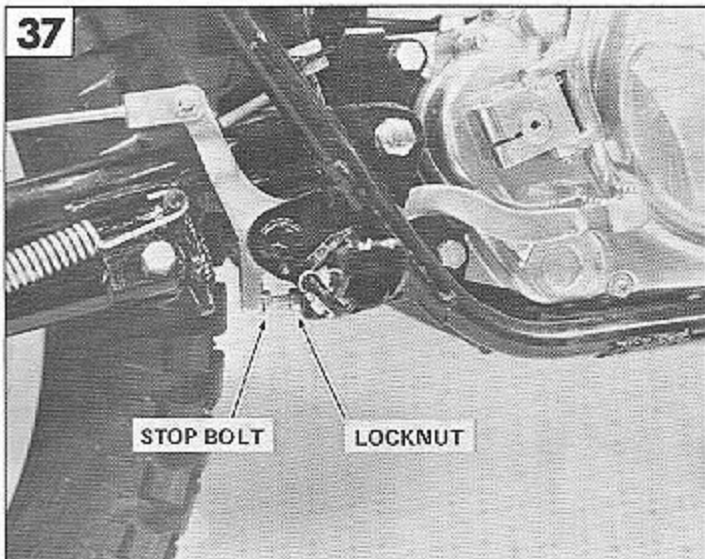

Adjust rear brake. At rest, brake pedal should be approximately level with footpeg. If not, loosen locknut on rest bolt. Adjust rest stop bolt until pedal is even with footpeg. Tighten locknut on rest stop bolt.

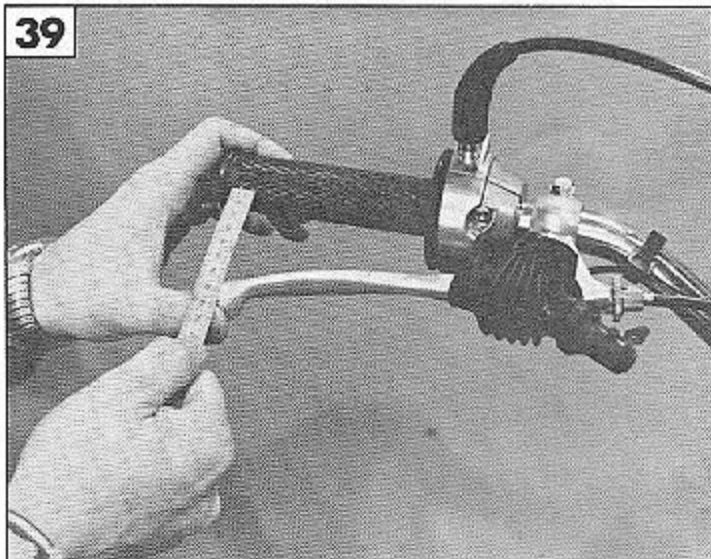

Adjust front brake. When fully applied there should be a 55-65mm gap between throttle grip and end of brake lever. If not:

- Screw in upper brake cable adjuster all the way.

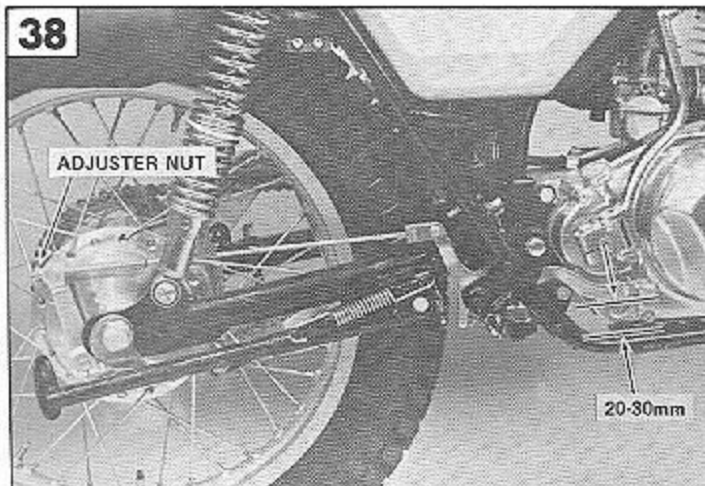

Brake pedal should travel 20-30mm before full application. Adjust travel with adjuster nut on rear end of brake rod.

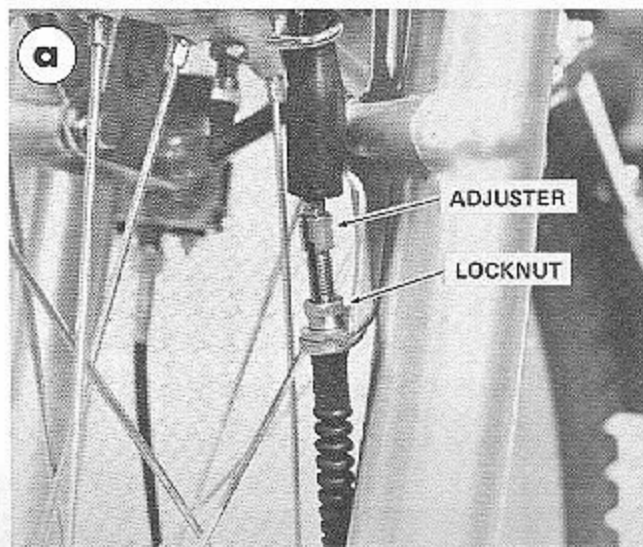

- Raise dust cover on lower brake cable adjuster.
- Turn adjuster on lower end of brake cable to obtain required clearance at brake lever.

Finish adjustment at upper brake cable adjuster, if required. Tighten upper and lower adjuster locknuts. Lubricate both cable end fittings. Replace dust covers.

40

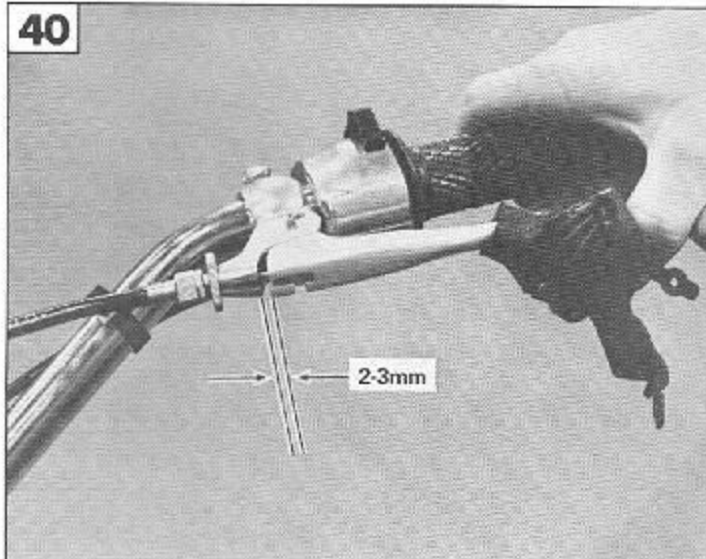

Adjust clutch. Loosen clutch cable locknut and turn thumb wheel adjuster to get 2-3mm cable play.

If correct play cannot be obtained at lever adjuster:

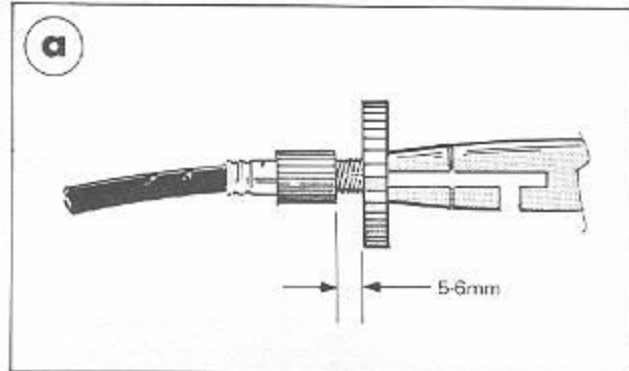

Set hand lever adjuster so there is 5-6mm between adjuster and locknut, with the locknut tight against the lever bracket. Raise dust cover at bottom end of clutch cable.

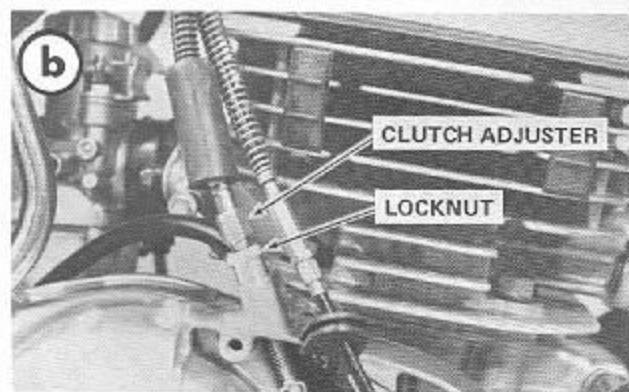

Loosen lower adjuster locknut, and back out adjuster to take up all cable play. Tighten locknut. Readjust thumb wheel at hand lever for 2-3mm play, and tighten locknut. Lubricate cable end fittings. Replace dust covers.

41

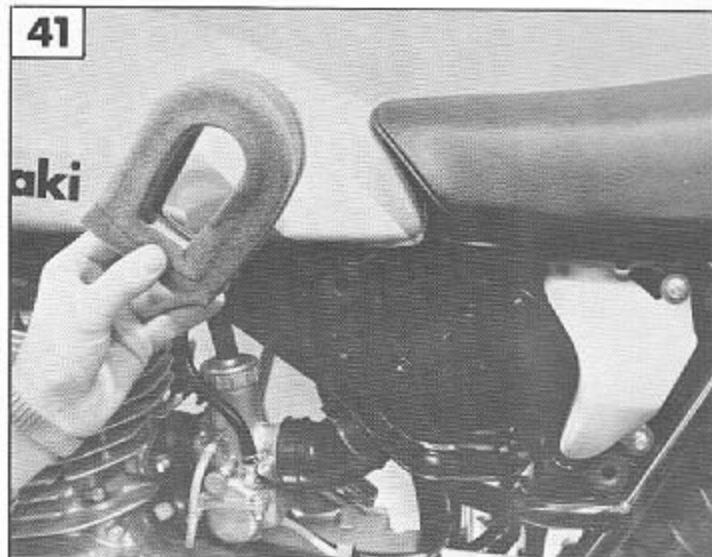

Remove and oil foam air filter:

- Remove left side cover. Remove 3 nuts, lockwashers, and flat washers holding air filter box cover.

**CAUTION:** WET THE ELEMENT IN A WELL VENTILATED AREA AND TAKE CARE THAT THERE ARE NO SPARKS OR FLAME ANYWHERE NEAR THE WORKING AREA.

- Soak element in 20:1 gasoline/oil mixture (20 parts gasoline:1 part oil). Shake off excess, wrap element in clean cloth, and squeeze dry. Fit element back in air cleaner housing.

**NOTE:** INSTALL THE ELEMENT CAREFULLY TO KEEP UNFILTERED AIR FROM ENTERING THE ENGINE.

- Replace air filter box cover, flat washers, lockwashers and nuts; and left side cover.

42

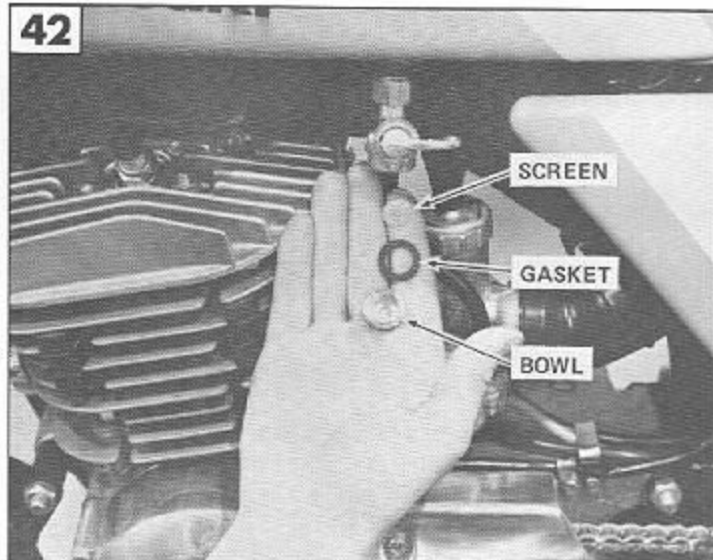

Remove and clean fuel cock filter bowl. Replace bowl with gasket and filter screen.



43

Cawasaki

FUEL COCK

250

Remove gas tank cap and fuel cock. If there is shot peen or debris in fuel tank, it must be cleaned. Install fuel cock, and fill tank with specified gasoline. Check for leaks in tank and fuel cock. Check cap vent by blowing through it.

**WARNING:** FILL THE TANK IN A WELL VENTILATED AREA, AND TAKE CARE THAT THERE ARE NO SPARKS OR OPEN FLAME ANYWHERE NEAR THE WORK AREA.

46

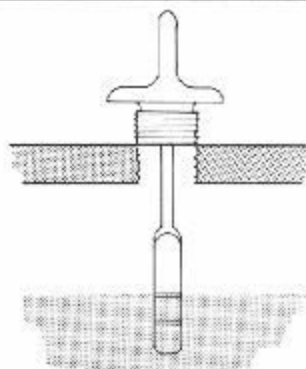

Turn engine over several times with kickstarter. Stand motorcycle vertical and check oil level with dipstick.

**NOTE:** DO NOT SCREW DIPSTICK INTO ENGINE COVER TO CHECK OIL LEVEL.

Oil level should reach between marks on dipstick. Replace dipstick with o-ring.

44

DRAIN PLUG

Remove transmission drain plug, drain shipping oil, and re-install plug with o-ring. Torque transmission drain plug to 1.3 kg-m (9 ft-lbs).

47

SUPPLY  
BANJO  
BOLT

Remove oil pump cover from right side of engine, loosen banjo bolt on line from oil tank, and drain tank. Tighten banjo bolt temporarily.

45

250 Trial

CRAWASAKI

Remove oil filler dipstick and pour in 1.2 liter of SAE 10W30 or 10W40 oil.

48

250 Trial

Remove left side cover, loosen seat mounting bolts, and slip seat off to rear.



49



Fill engine oil tank with 2-stroke oil.

**CAUTION:** CHECK THAT OIL TANK VENT HOSE IS NOT PINCHED OR KINKED. THIS COULD RESTRICT OIL SUPPLY, RESULTING IN SERIOUS ENGINE DAMAGE.

Replace oil tank cap, side cover, and seat. Tighten seat mounting bolts securely.

50

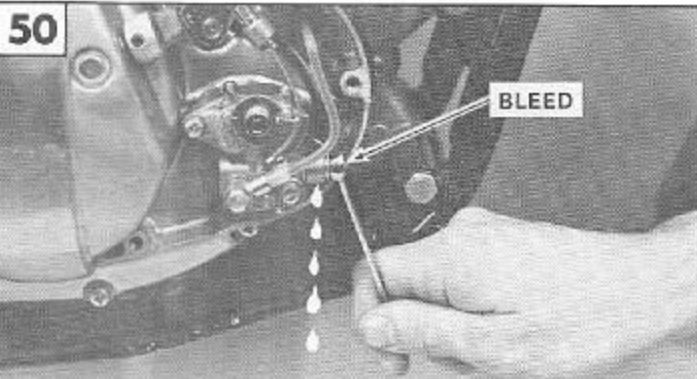

Again, loosen banjo bolt at supply line to oil pump, and bleed line from tank. Tighten bolt to 45 kg-cm (39 in-lb).

**CAUTION:** TO AVOID POSSIBLE ENGINE DAMAGE, MAKE CERTAIN THAT THE OIL FLOWS STEADILY WITHOUT AIR BUBBLES.

51

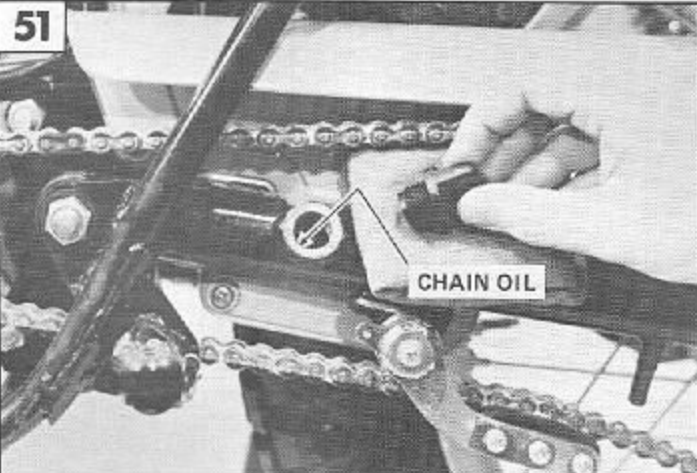

Fill swing arm reservoir with SAE 90 weight gear oil, and install plug securely.

52



Remove preservative from spark plug with electrical contact cleaner. Set gap at 0.6-0.7mm (.025 in). Replace spark plug. Torque to 2.7 kg-m (20 ft-lbs).

53

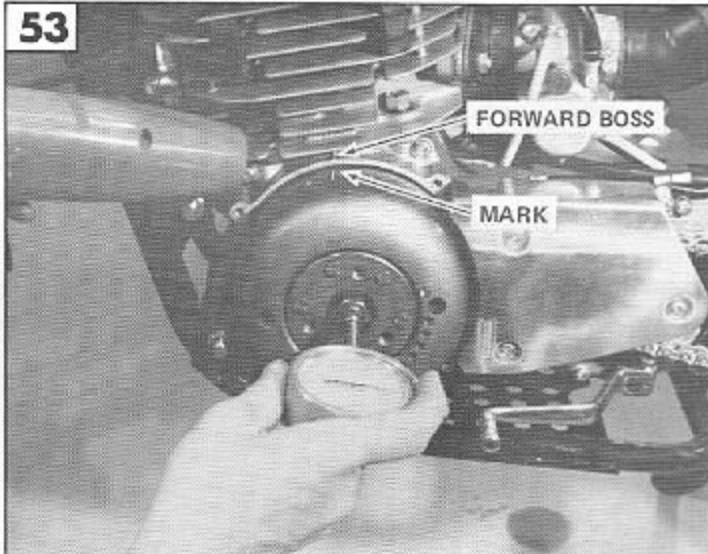

Check dynamic timing: Remove magneto cover. Connect strobe light to spark plug lead, and start engine. Use hand held tachometer and strobe light to check that mark on flywheel aligns with forward boss on crankcase at approximately 4000 RPM. If marks do not align, refer to KT250 Shop Manual, page 12. Reinstall magneto cover.

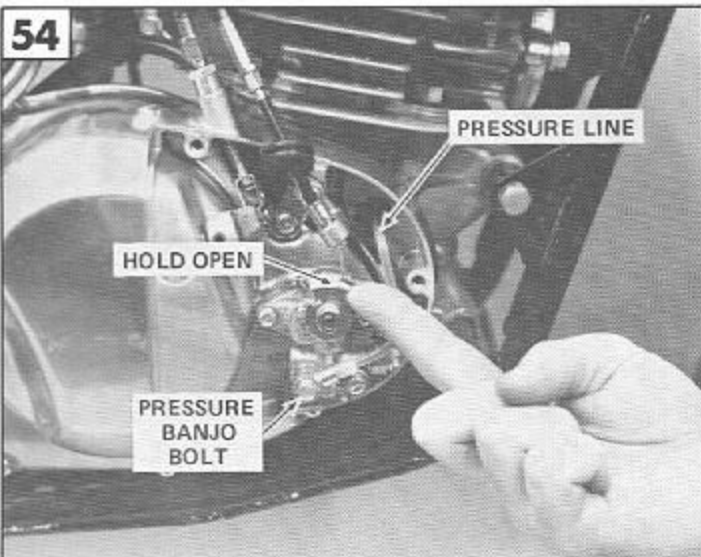

Bleed oil pump: Start engine and hold at approximately 2000 RPM. Push oil pump lever to full open position and continue running engine until air bubbles are gone from pressure line and exhaust begins to smoke heavily.

**CAUTION:** IF EXHAUST DOES NOT SHOW SMOKE, OR IF BUBBLES REMAIN IN PRESSURE LINE, CHECK FOR LINE STOPPAGE OR LOOSE CONNECTIONS.

Check oil pressure line banjo bolt. Tighten if required to 45 kg-cm (39 in-lb). Do not replace oil pump cover.

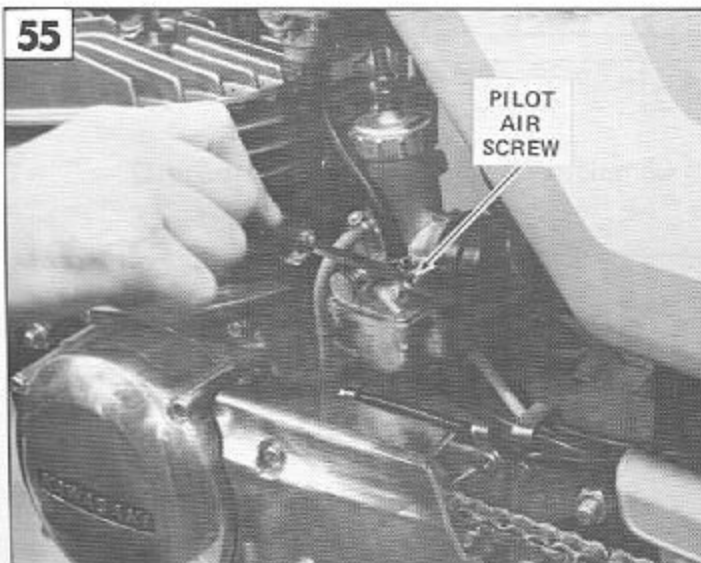

Turn pilot air screw in until it seats lightly, then back out 1-1/2 turns.

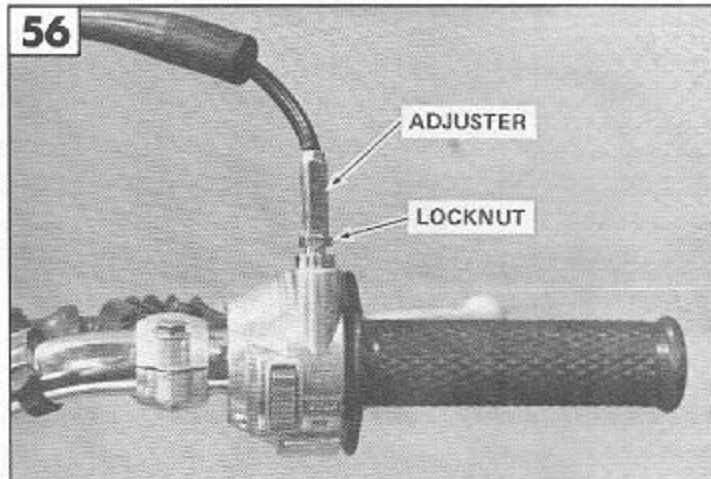

Raise dust cover at throttle twistgrip cable. Loosen locknut and screw in adjuster to get maximum cable free play.

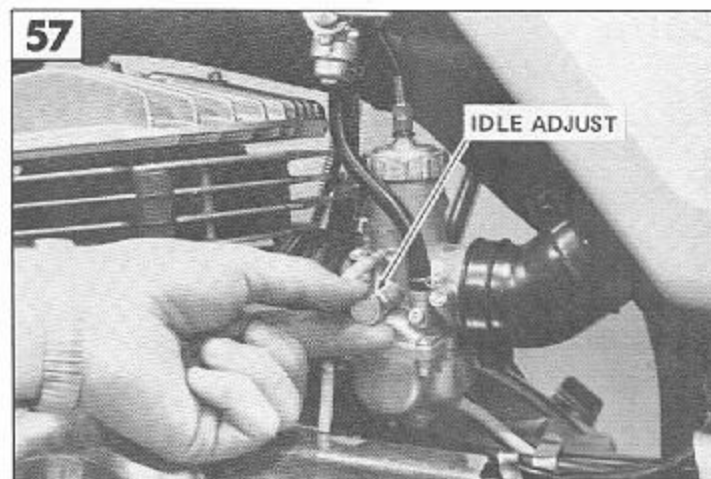

Start and warm up engine. Adjust idle speed so that engine stops when the throttle is released. Turn off engine.

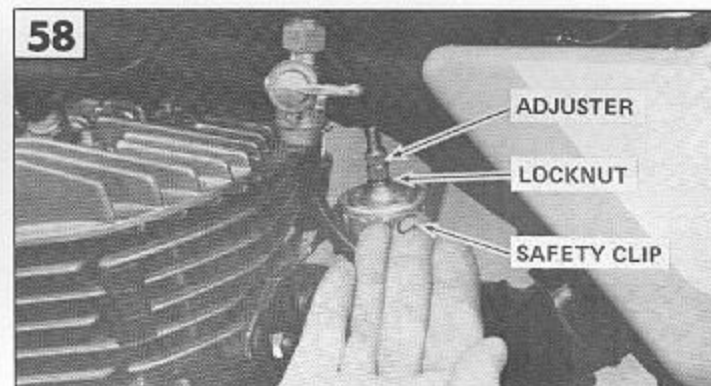

Raise dust cover on top of carburetor, remove safety clip, loosen locknut, and turn adjuster to remove all cable free play. Tighten locknut, replace clip and dust cover.

**CAUTION:** THE CABLE SAFETY CLIP MUST BE INSTALLED.

69

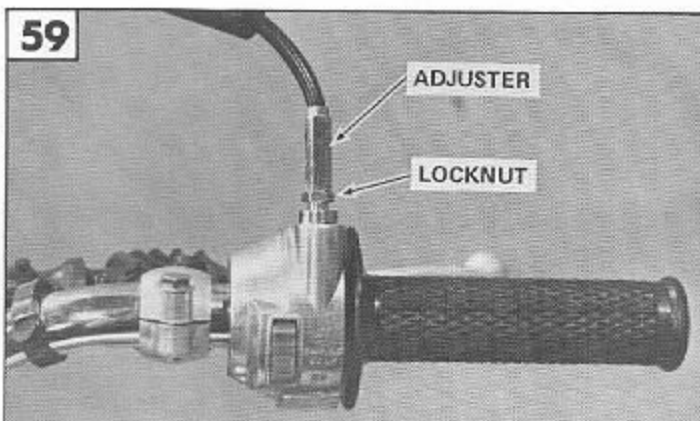

ADJUSTER

LOCKNUT

Turn cable adjuster at throttle twist grip to get "zero" cable free play.

Tighten locknut and replace dust cover at twistgrip.

60

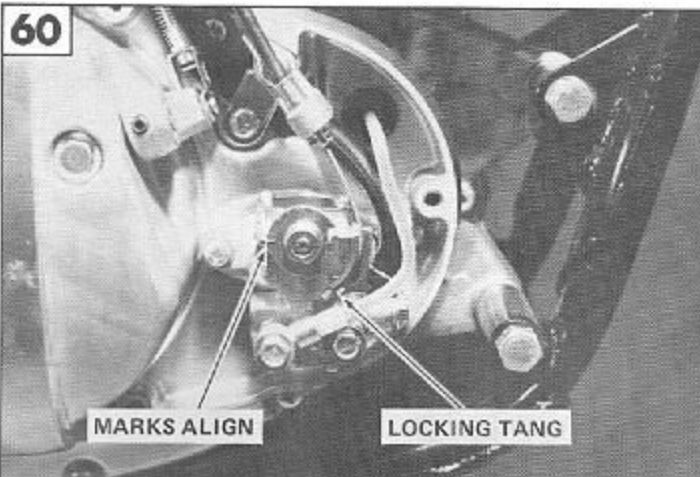

MARKS ALIGN

LOCKING TANG

Adjust oil pump: With throttle closed, mark (-) on oil pump control lever should align with mark on oil pump body.

61

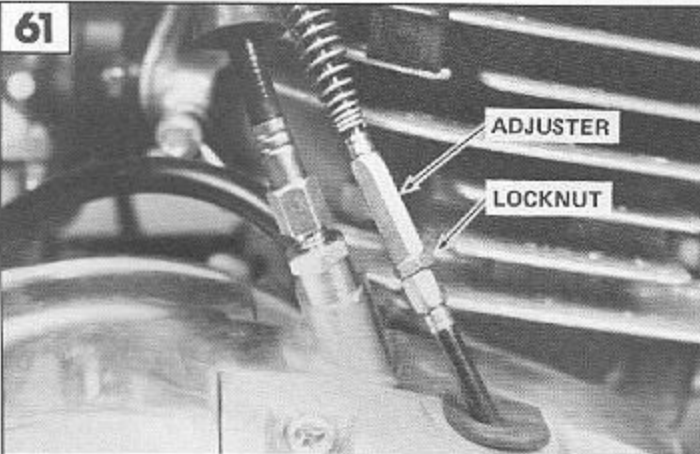

ADJUSTER

LOCKNUT

If not, loosen locknut on oil pump control cable, and turn adjuster to align marks. Tighten locknut. Make sure locking tang is crimped over oil pump cable.

62

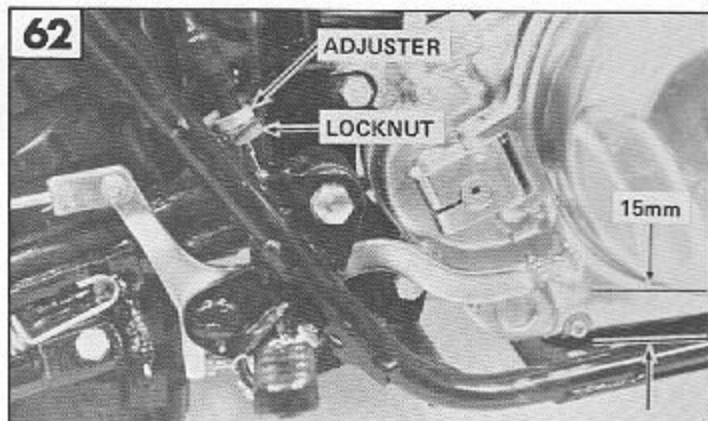

ADJUSTER

LOCKNUT

15mm

Adjust brake light switch (engine must be running). Brake pedal should travel approximately 15mm before brake light goes on. If not:

- Loosen light switch locknut.
- Turn light switch adjuster nut until proper action is achieved.

**NOTE:** AVOID TURNING SWITCH BODY TO PREVENT TWISTING ELECTRICAL WIRES.

- Retighten locknut.

63

Check fasteners shown on page 19. Tighten if required.

64

Complete Test Ride Checklist on page 17.

## PREPARATION COMPLETE

**TEST RIDE THE MOTORCYCLE – CHECK:****● CONTROL CABLES**

The throttle, clutch, and front brake must work without binding in any steering position. Check that the throttle cable is free enough so that the engine will die when the twistgrip is released (in any steering position).

**● STEERING**

Action is free from lock-to-lock.

**● SUSPENSION**

Check operation front and rear.

**● ENGINE**

Kickstarter works properly and engine starts promptly.

Good throttle response and return.

Exhaust smoke present but not excessive.

**● TRANSMISSION & CLUTCH**

Smooth operation

**● BRAKES**

Adequate, smooth stopping power.

**● SPEEDOMETER**

Check operation.

**● ELECTRICAL SYSTEM**

Headlight – check high and low beams.

Taillight – check operation.

Brakelight – check operation.

Horn – check operation.

**● ENGINE STOP BUTTON WORKS****● NO UNUSUAL NOISES****● NO FUEL OR OIL LEAKS**



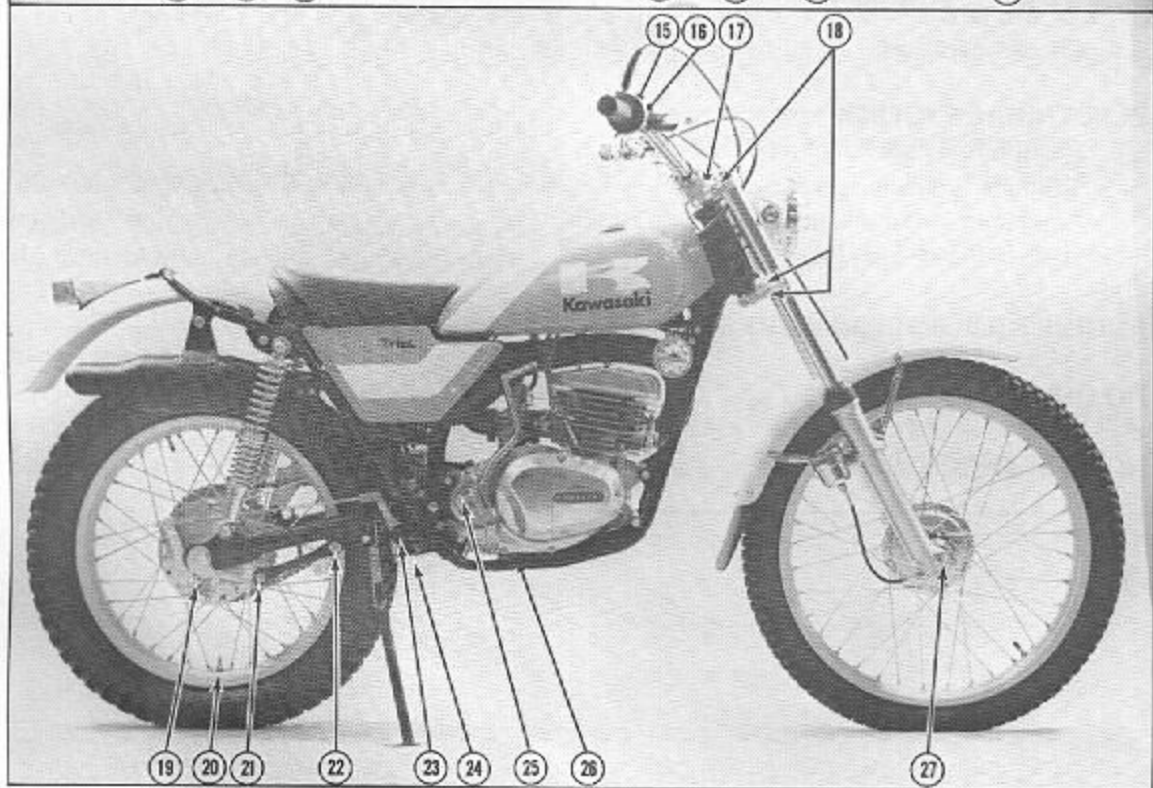
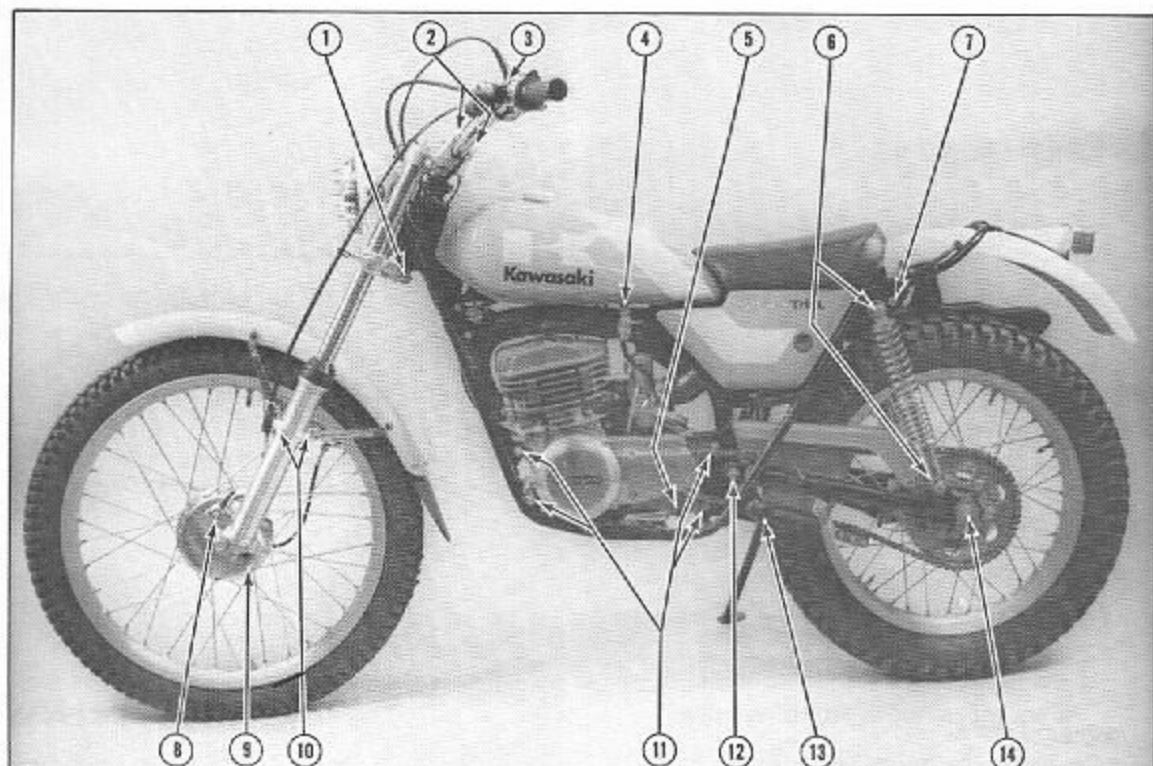

CHECK AND TIGHTEN AS REQUIRED

ITEM	DESCRIPTION	QUANTITY	TOOL SIZE (mm)	TORQUE
1	Steering Stem Base Allen Bolt		8mm	5.2 kg-m (38 ft-lb)
2	Handlebar Clamp Bolts	4	13	1.9 kg-m (13 ft-lb)
3	Clutch Lever Pivot Nut		8	
4	Fuel Cock Nut		19	
5	Shift Pedal Bolt		10	
6	Shock Absorber Screws	4		
7	Seat Bolts	2	13	
8	Front Brake Cam Lever Bolt		10	0.7 kg-m (5 ft-lb)
9	Front Brake Panel Stopper Bolt		17	5.5 kg-m (40 ft-lb)
10	Front Fender Bolts	4	13	1.9 kg-m (14 ft-lb)
11	Engine Mount Nuts	4	17	4.0 kg-m (30 ft-lb)
12	Swingarm Pivot Nut		19	7.3 kg-m (53 ft-lb)
13	Footpeg Cotter Pins	2 cotter pins		
14	Rear Axle Nut	w/cotter pin	24	9.0 kg-m (65 ft-lb)
15	Twistgrip Case Screws	2		
16	Brake Lever Pivot Nut		8	
17	Steering Stem Head Bolt		19	5.8 kg-m (42 ft-lb)
18	Fork Clamp Allen Bolts	6	6	2.2 kg-m (16 ft-lb)
19	Rear Brake Cam Lever Bolt		10	0.7 kg-m (5 ft-lb)
20	Bead Protector Nuts	2 Rear 1 Front	12	
21	Torque Link Nut	w/cotter pin	14	2.8 kg-m (21 ft-lb)
22	Torque Link Cotter Pin	cotter pin		
23	Brake Pedal Pivot Circlip	circlip		
24	Brake Pedal Stopper Locknut		10	
25	Kick Pedal Bolt		13	
26	Transmission Drain Plug		17	1.25 kg-m (9 ft-lb)
27	Front Axle Nut	w/cotter pin	17	5.8 kg-m (42 ft-lb)

The table below, relating tightening torque to thread diameter and pitch, lists the basic torque for the bolts and nuts used on Kawasaki Motorcycles. However, the actual torque that is necessary may vary among bolts and nuts with the same thread diameter and pitch. The bolts and nuts listed on pg. 19 vary to a greater or lesser extent from what is given in this table. Refer to this table for only the bolts and nuts not included in the table on Pg. 19. All of these values are for use with dry solvent cleaned threads.

Coarse threads

dia (mm)	pitch (mm)	kg-m	ft-lbs
5	0.90	0.35~0.50	2.5~3.5
6	1.00	0.6~0.9	4.5~6.5
8	1.25	1.6~2.2	11.5~16.0
10	1.50	3.1~4.2	22~30
12	1.75	5.4~7.5	39~54
14	2.00	8.3~11.5	60~83
16	2.00	13~18	94~130
18	2.50	18~25	130~181
20	2.50	26~35	188~253

Fine threads

dia (mm)	pitch (mm)	kg-m	ft-lbs
5	0.50	0.35~0.50	2.5~3.5
6	0.75	0.6~0.8	4.5~5.5
8	1.00	1.4~1.9	10.0~13.5
10	1.25	2.6~3.5	19.0~25
12	1.50	4.5~6.2	33~45
14	1.50	7.4~10.2	54~74
16	1.50	11.5~16	83~116
18	1.50	17~23	123~166
20	1.50	23~33	166~239

## KT 250 SPECIFICATIONS

### ENGINE

Type	2-stroke, single cylinder, piston valve	
Bore and stroke	69.5 x 64.9 mm	
Displacement	246 cc	
Compression ratio	6.5:1	
Cranking Pressure	11.5 kg/cm <sup>2</sup> (164 psi)	
Maximum horsepower	16 HP @6,500 rpm	
Maximum torque	1.9 kg-m @4,000 rpm	
Port timing		
Intake	Open	68° BTDC
	Close	68° ATDC
Scavenging	Open	53° BBDC
	Close	53° ABDC
Exhaust	Open	76° BBDC
	Close	76° ABDC
Lubrication system	Superlube (Oil injection)	
Engine oil	2-stroke oil	
Starting system	Primary kick	
Ignition system	Electronic CDI	
Ignition timing	23° BTDC/3.7 mm BTDC @4,000 rpm	
Spark Plug	NGK B7HS	

### CARBURETOR

	Mikuni VM26SC/Primary
I.D. Mark	KT250
Main Jet	#85R
Air Jet	#2.5
Jet Needle	5D1-3rd
Needle Jet/Primary Choke	#0-8/8 mm
Badge #	#172
Cutaway	#2.0
Pilot Jet	#30
Air Screw (turns out)	1½
Service Fuel Level	5 mm
Float Level	24 mm

### LUBRICANTS

Engine Oil Tank	250 cc (8.5 U.S. fl oz) 2-stroke injection oil
Transmission	1.2 liter (40 U.S. fl oz) SAE 10W30 or 10W40 oil
Chain Oil	SAE 90 weight gear oil
Fork Oil	165 cc (5.5 U.S. fl oz) SAE 10W oil 492 mm from top



# WIRING DIAGRAM

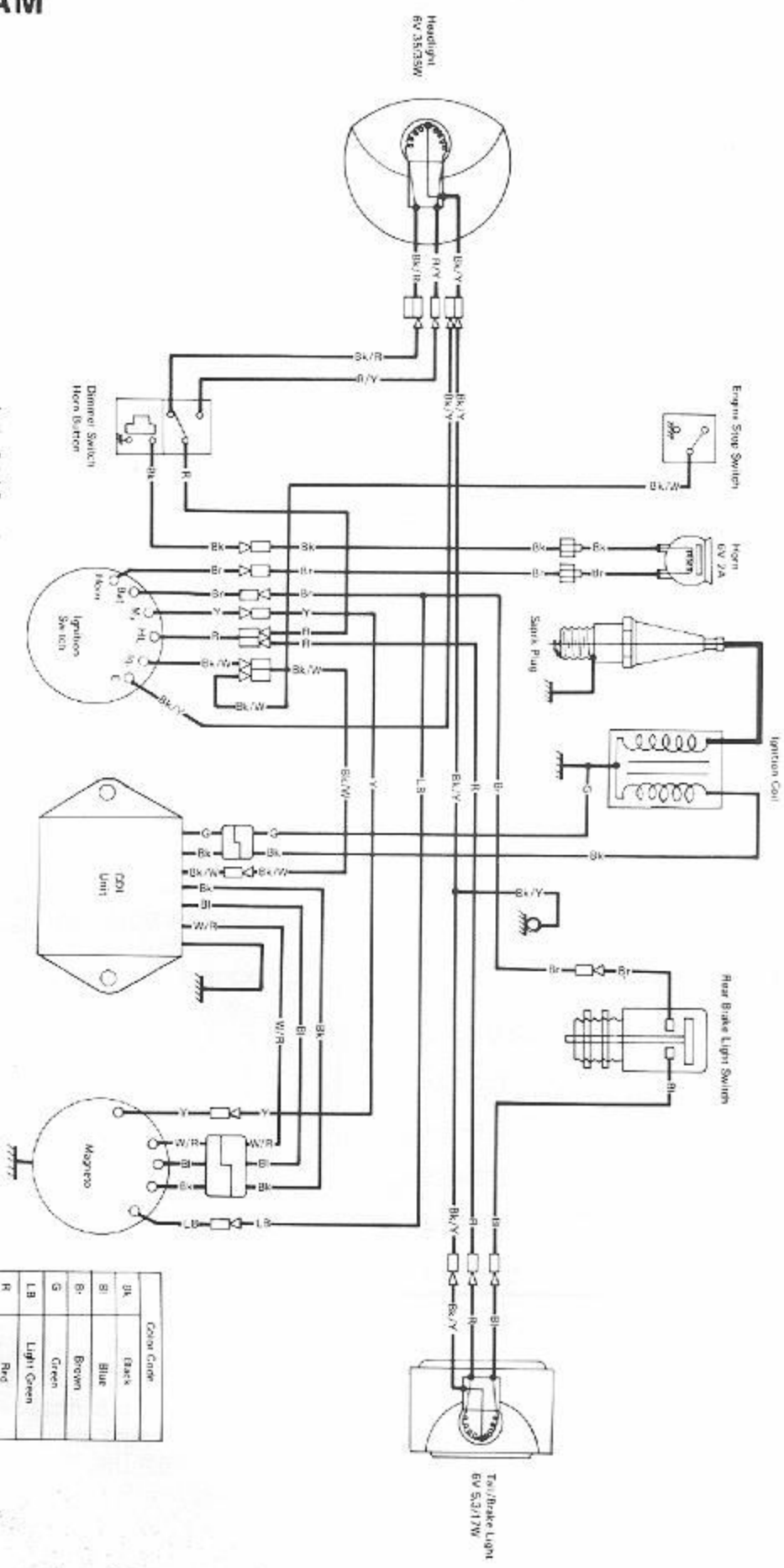

Ignition Switch Connections

	Ign	E	H.L.	M3	Ign	Motor
OFF	BK/W	BK/V	R	Y	Bl	B
DAY						
NIGHT						

Color Code	Color
BK	Black
Bl	Blue
Br	Brown
G	Green
LB	Light Green
R	Red
Y	Yellow
W	White

(177) II