

Ref	Description	Part No.	Quantity
1	450 cc Kit	99970-0003	
2	● Crankshaft Assy	13031-1059	
3*	●● Connecting Rod Assy	13044-5011	1
4	●● R.H. Crankshaft	13037-1113	1
5	●● L.H. Crankshaft	13037-1112	1
6	● Spacer	92026-1094	1
7*	● Gasket	11009-1130	2
8	● Muffler	18002-1185	1
--	● Installation Instructions	99963-0048-01	1

*Standard KX420 parts.

Installation Procedure:

- Remove engine crankcase halves.
 - See Owner's/Service Manual (P/N 99963-0041-01) for detailed procedure (pg. 30-33).
- Remove metal from both crankcase halves as shown in the illustration for connecting rod clearance.
 - Mark the crankcase halves for metal removal as shown.

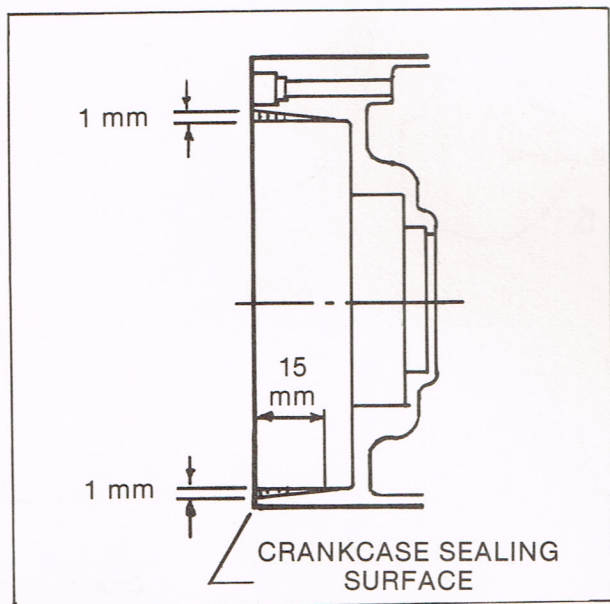
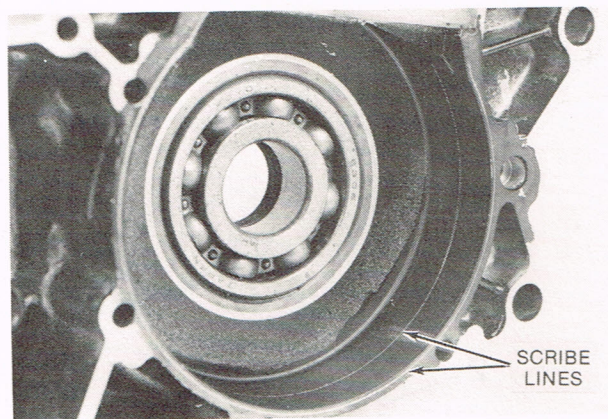

CAUTION

If the bearings are to be left in the cases, mask them carefully with tape.

- Carefully scrape the aluminum away with a gasket scraper or use a rotary file.

CAUTION

Do not remove too much material or the crankcase may not seal properly and may fail.

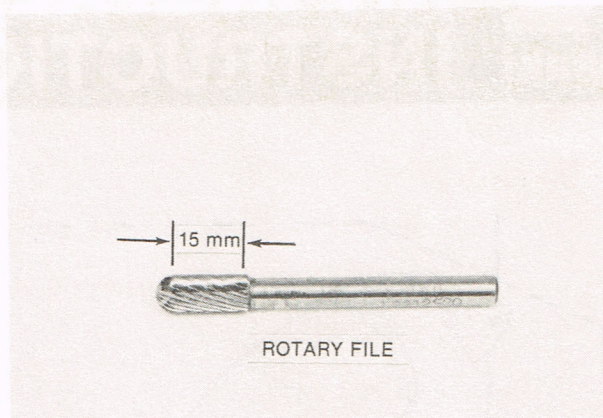

- Use a straightedge to be sure the cutaway surface is flat.

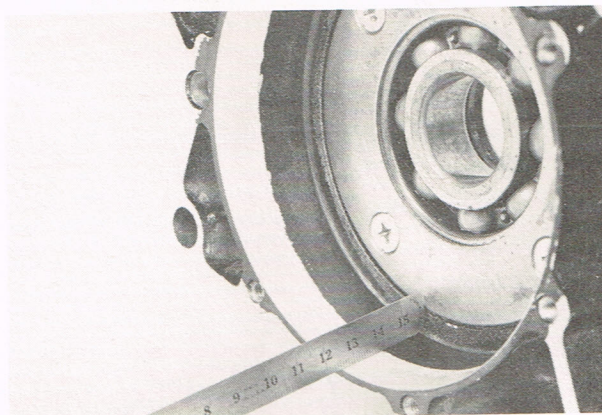

- Smooth the new surface with 180 grit aluminum oxide paper or a polishing stone in a rotary grinder.
- Clean the cases thoroughly and remove the masking from the bearings.
- Temporarily install the new crankshaft assembly in the crankcase halves to be sure that the connecting rod big end does not touch the crankcase.
- Assemble the lower end of the engine with the new crankshaft assembly.
 - See Owner's/Service Manual (P/N 99963-0041-01) for detailed procedure (pg. 33-36).
- To eliminate the possibility of the piston's exhaust side skirt from hitting the crankshaft, it must be modified. Carefully file away the corners of the skirt on the exhaust side only, as shown.
 - Polish out all the file marks with 180 grit aluminum oxide paper.

CAUTION

Be careful not to distort the piston by fastening it too tightly in a vise during filing.

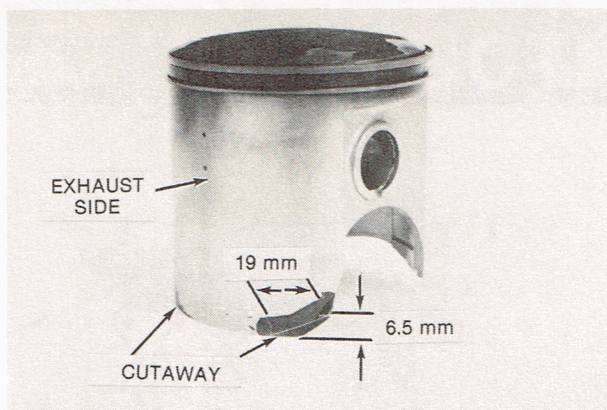

- Install the top end of the engine using the cylinder spacer and two gaskets as shown below.

- Use one gasket on each side of the spacer.

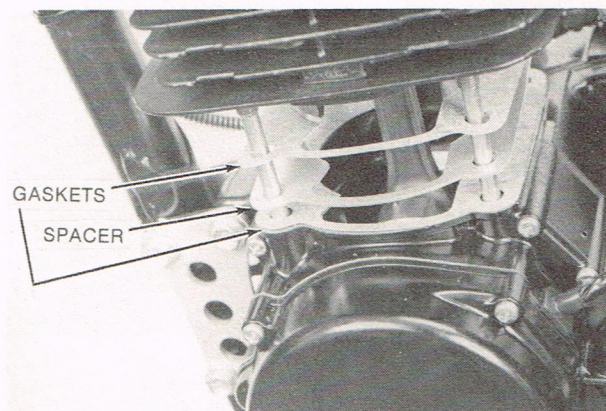

- Be sure the port areas in the crankcase, spacer, and gaskets are aligned.
- See Owner's/Service Manual (P/N 99963-0041-01) for detailed procedure and torque values (pg. 36-37).

- Install the engine using the new muffler.

Carburetion:

- Use the standard carburetor jetting on the KX420-A2 (1981 model). Replace the KX420-A1 (1980 model) carburetor with the KX420-A2 unit (P/N 16001-1390).